



Implementation of a Very Low Cost Portable SpaceWire Monitor and Debugger

International SpaceWire Conference 2008

Paul Jaffe
Naval Center for Space Technology
Washington, DC, USA
paul.jaffe@nrl.navy.mil
+001 202-767-6616

Keith Leisses
Dynamic Engineering 150 DuBois St.
#C Santa Cruz, CA 95060, USA
sales@dyneng.com
+001 (831) 457 8891



The Need for a Very Low Cost SpaceWire Debugger



- An objection raised to the use of SpaceWire is that it is not as widespread as other interfaces proposed for space. MIL-STD 1553, RS-422, IEEE-1394 variants, Ethernet, I2C, and USB have been posed as alternatives.
- Many factors go into interface selection, including data transfer capacity, prior spaceflight heritage, power consumption, and development complexity. Often price and availability of test equipment are cited as a salient variables to be weighed.
- Historically, the costs of interface test equipment are generally dwarfed by other space program cost elements, such as flight hardware procurement and staffing.
- This is changing as the prevalence of high school and university student satellite projects joins ranks with small aerospace companies who may be developing only one component or a small experiment. These entities may be severely cost-constrained and may depend on uncompensated student labor and donated launch opportunities.



Rough Test Interface Costs



Approximate cost ranges of ground test equipment for various interfaces - prices \$USD				
Interface	Hardware needed	Software needed	2008 ~cost range	Suppliers
MIL-STD-1553	Interface card	Incl. with hardware	\$500-\$2,000	SBS, Paravant, others
RS-422	USB or RS232 to 422 conv	Free d/l: Terminal software	\$100-\$300	Black Box, B&B, others
I2C	USB-I2C converter	Incl. with hardware	\$250-\$750	MCC, Total Phase, others
USB	(included with PC)	Free d/l: USBET, USBTester	\$0	usb.org, Jungo, others
IEEE-1394	(included with many PCs)	Free d/l: libdc1394, VHPD1394	\$0-\$1500	sourceforge.net, Thesycon
Ethernet	(Included with PC)	Free d/l: tcpdump, Wireshark	\$0	tcpdump.org, wireshark.org
SpaceWire	Interface card or converter	Incl. with hardware	\$3,500-\$12,000+	Star-Dundee, 4Links, others
	DESWBO and LA	Incl. with USB logic analyzer	\$900+LA*	Dynamic Engineering

*appropriate USB logic analyzers (LA) range from \$149 to \$1500+

- Cost of time to become familiar with hardware and software tools, which is considerable in some case, is not included.
- The level of capability provided by the options in the table is highly variable

The idea: combine an inexpensive USB logic analyzer with an inexpensive SpaceWire breakout box for SpaceWire monitoring and debugging.



USB Logic Analyzers



- Logic analyzers have gone from being cumbersome, complex, expensive pieces of equipment that cost tens of thousands of dollars to small, easy-to-use devices available at near commodity pricing. This has been enabled in large part by two advances:
 - the ubiquity of the personal computer
 - the comparatively recent rise of the USB interface
- By 2008, several billion USB interface devices had entered the market, and USB had become the dominant interface in the personal computer realm.
- Over a dozen different types of USB logic analyzers were available for less than \$1,000 US, offering amenities such as integrated oscilloscopes, pattern generators, as many as 34 channels per device, and up to oscillator frequencies of 1 GHz.



DigiView DV1-100



- 18 Channels @ 100 MHz (10ns)
- USB interface and power source for portability
- Real time Hardware Compression.
- Eliminates Resolution vs. Depth tradeoffs.
- Compression Ratio up to 256,000:1 depending on activity.
- Trigger on rising, falling or transition of any channel.
- Multi-channel High, low and don't care trigger qualifier.
- Pre-trigger and post-trigger data capture.



Information and image downloaded from http://www.tech-tools.com/dv_dv1.htm



Dynamic Engineering DESWBO



- There are 24 test points for each node that are driven by the real-time signals from the SpaceWire character receivers
 - eight data bits
 - six credit count bits
 - Parallel data strobe
 - NULL received
 - FCT received
 - Timecode received
 - End-of-Packet
 - Error End-of-Packet
 - Credit error
 - Disconnect error
 - Escape error
 - Parity error
- DIN and SIN signals test points for each node from the LVDS receivers
- One test point for each node that is driven by the recovered clock
- Three ground test points per node to facilitate probe grounding.
- Powered by an included external 5-volt supply
- Cost: \$900 US

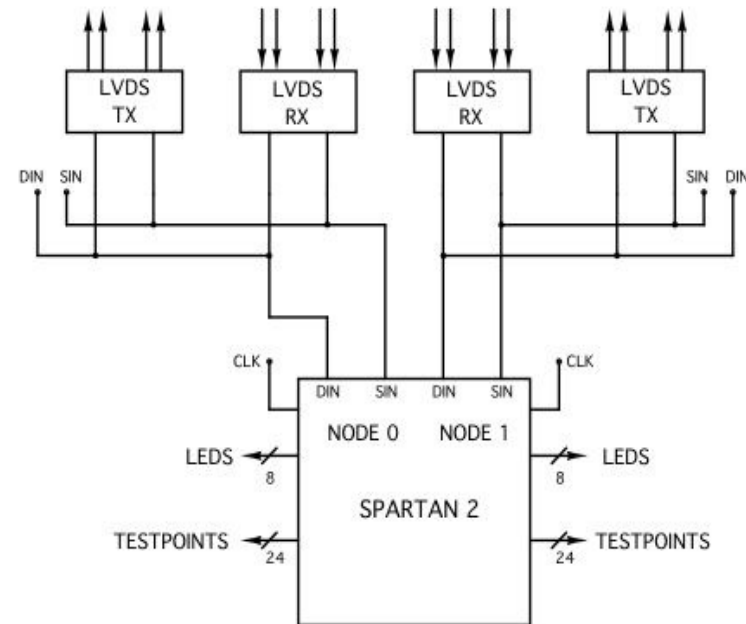



Monitoring the Link

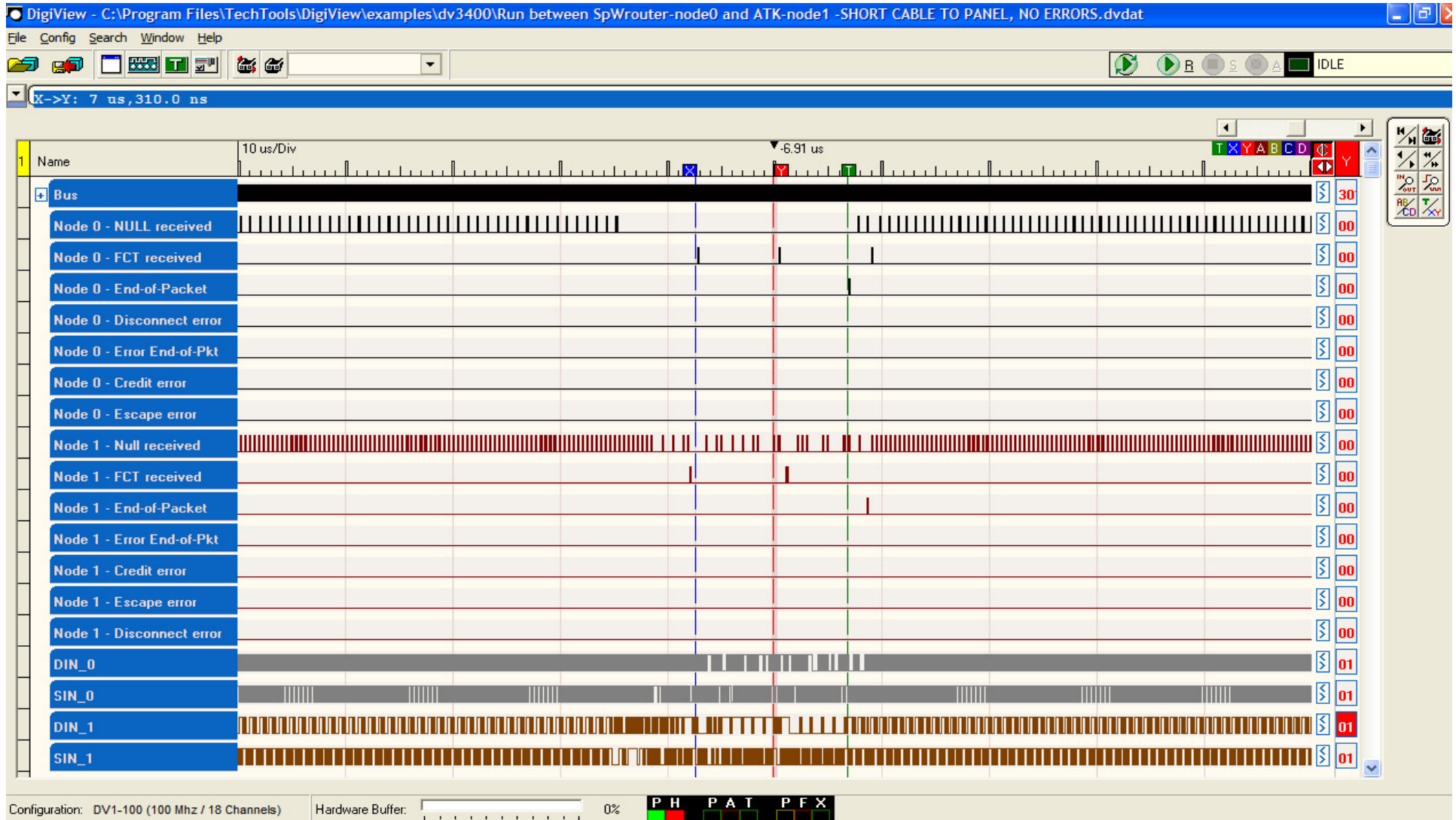



Inspecting Data & Strobe Signals

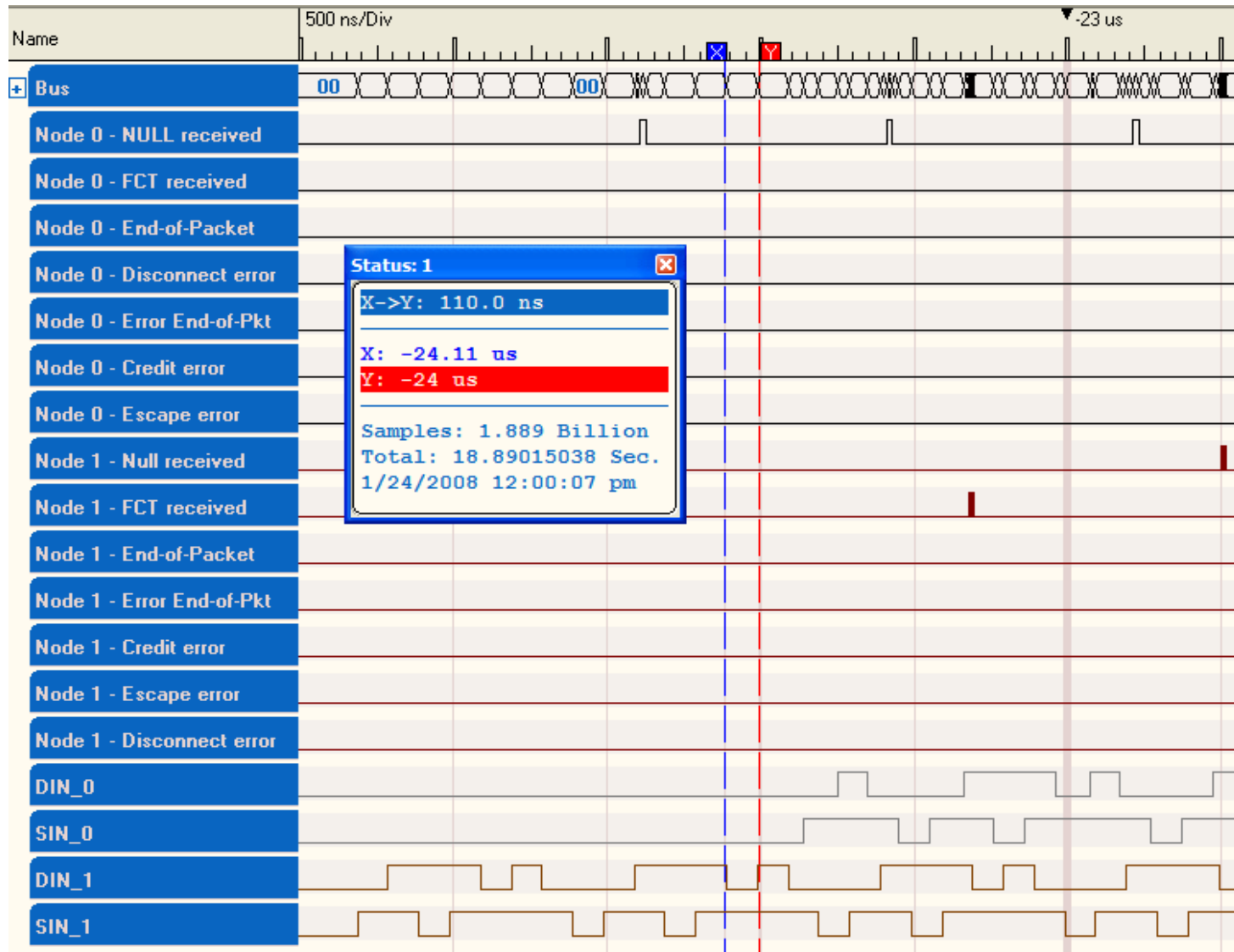



Use of the System



- This test resource has been used successfully to support TacSat-4, PnP Sat, Herschel II, and other satellite projects.

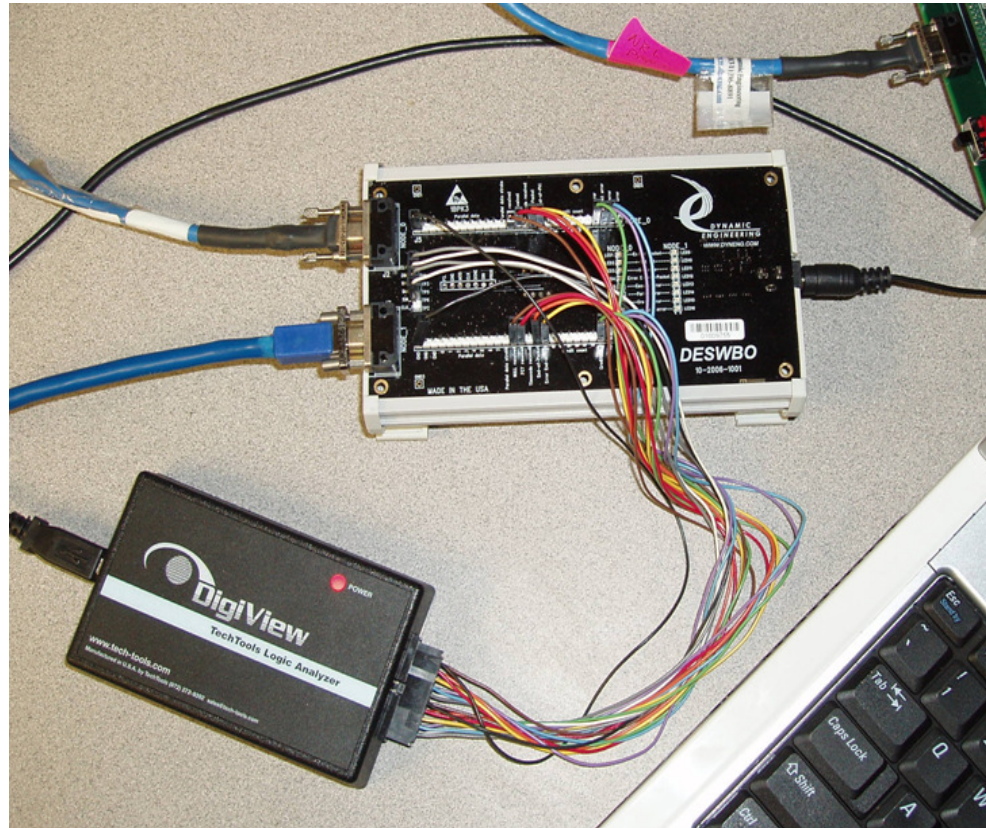

Combining an inexpensive USB logic analyzer with an inexpensive SpaceWire breakout box provides a portable, capable, resource for SpaceWire monitoring and debugging.